

# I.V. House 949XS TLC® Foot Splint

## IV Therapy Foot Splint / Directions

Single Use Only—Fits either foot, laterally or medially.

The TLC Foot Splint can be applied to foot/ankle before or after inserting IV and connecting to extension set or IV tubing.

**1.**

Orient the concave side of the splint facing upward and unroll the straps.

**2.**

Align the infant's ankle with the splint's middle opening. The heel should roughly coincide with the prominent curve at the outer edge of the splint.

Rotate the splint to position it laterally or medially, on a left or right foot.

**3.**

Slide strap under IV tubing and wrap the top strap around the lower leg and the splint.

Wrap the bottom strap over the toes and slip the free end through the hole in the splint near the toes.

Slip strap under loop of tubing at toe.

Lightly tension the straps as they wrap around the back of the splint.

Secure tubing at lower leg with final pass of strap.

**4.**

**Note:** Slip one finger beneath each strap to ensure the fabric is not so tight that it impedes circulation or infusion of IV fluids.

Use pre-attached Velcro® hook tabs to secure the ends of the straps.

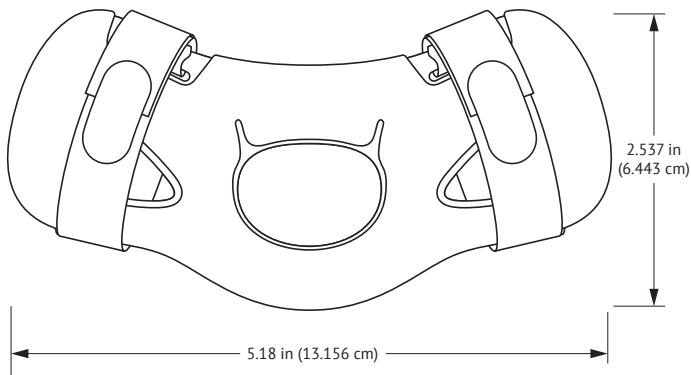

### 949XS TLC® Foot Splint

Fits most newborns ages 0–4 months, or weighing 2.5 to 7 kg (5.5 to 15 lb.)

Touch / Look / Compare



**I.V. HOUSE®**  
Protection Over and Above®

I.V. House, Inc. / St. Louis, MO 63146 USA

314-453-9200 / 800-530-0400 / FAX 314-453-9576 / IVinfo@ivhouse.com / www.ivhouse.com